

# Wallenius Marine

Leading the way towards truly sustainable shipping

# OUR VISION: "LEADING THE WAY TOWARDS TRULY SUSTAINABLE SHIPPING"

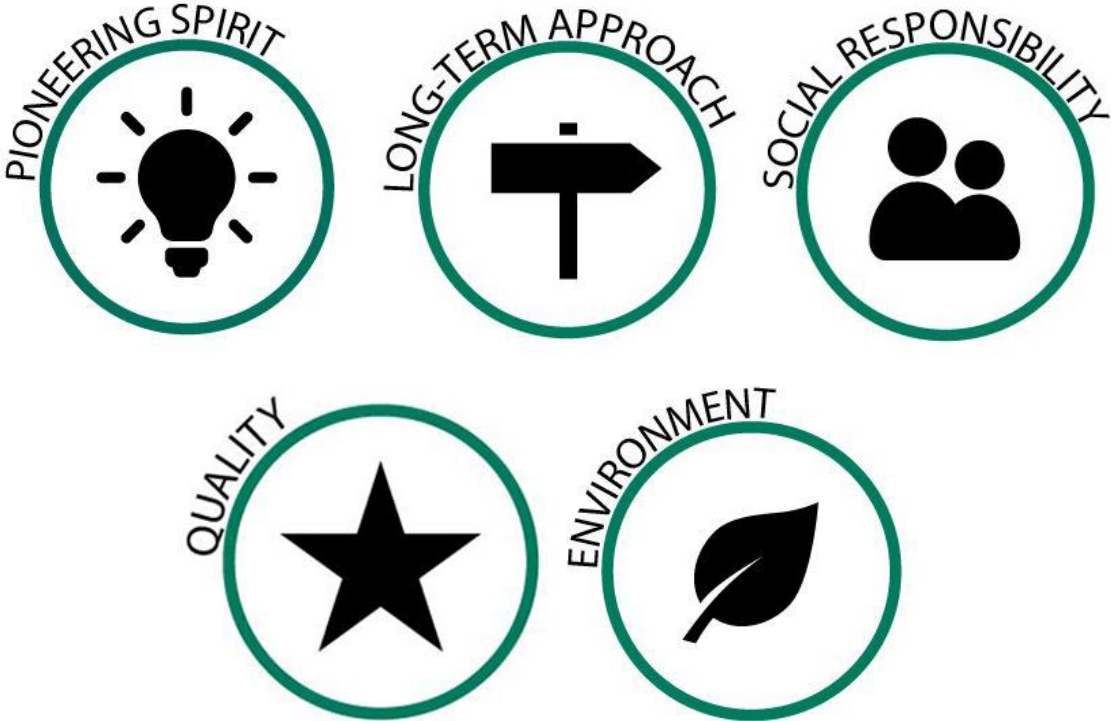

# ZERO



Roadmap mot vår vision om emissionsfria fartyg  
Utgör nu basen för våra nya designer

Roadmap för...:

- operation
- energibärare
- teknologi
- Wallenius' designer
- energianvändning
- emissioner
- Wallenius Marines kompetens



# ROADMAP FÖR ENERGI OCH EMISSIONER

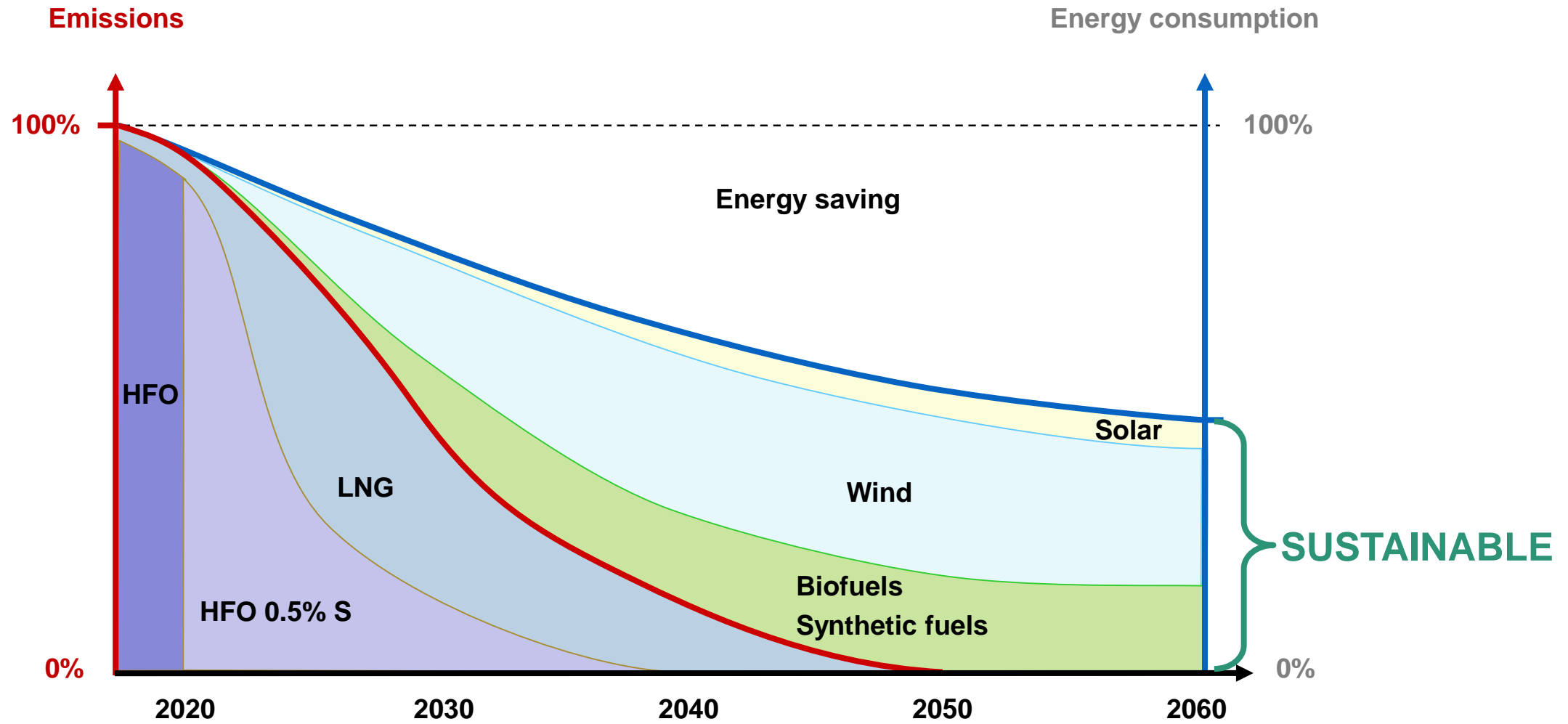

Sun < 0,5 MW



Wind < 3 MW



Waves < ? MW

$\Sigma \approx 3 \text{ MW}$



## **HERO class PCC 7000 cars**

Length 200 m, width 36 m

Displacement 35.000 tonnes

Today 40 ton bunker/day @ 17 knots



## **wPCC class 7000 cars**

Length 210 m, width 39 m

Displacement 32.000 tonnes

Target >90% reduction @ 10 knots

# WALLENIUS MARINE



# wPCC TIME PLAN

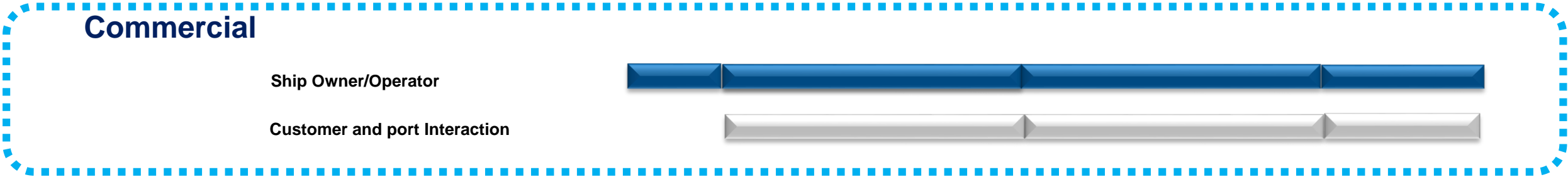
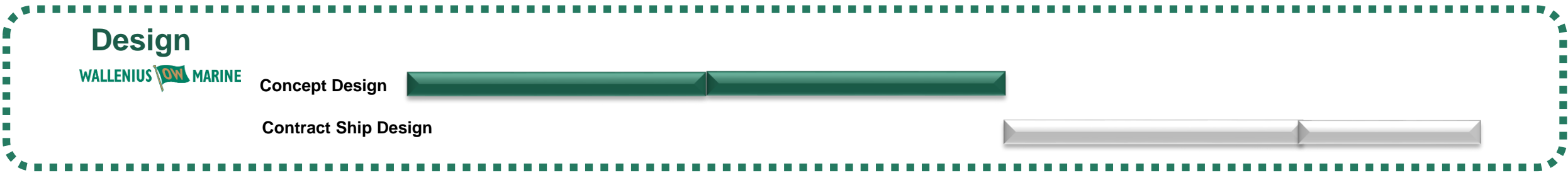



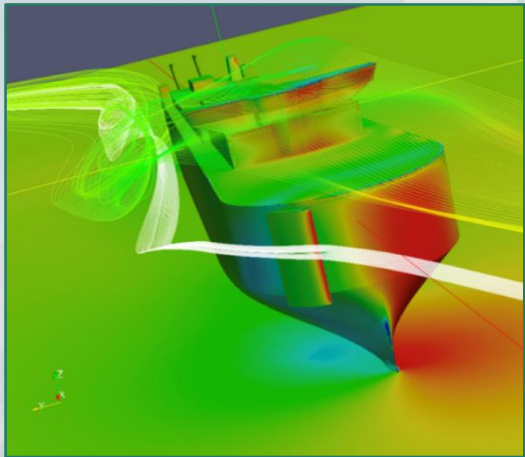
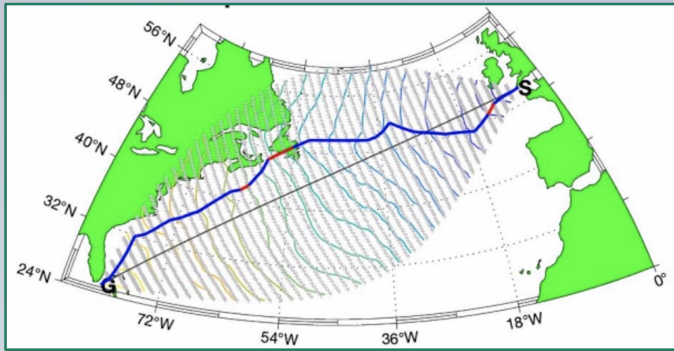

Rutt-  
optimierung

Fartygs-  
concept

Vingsegel-  
system

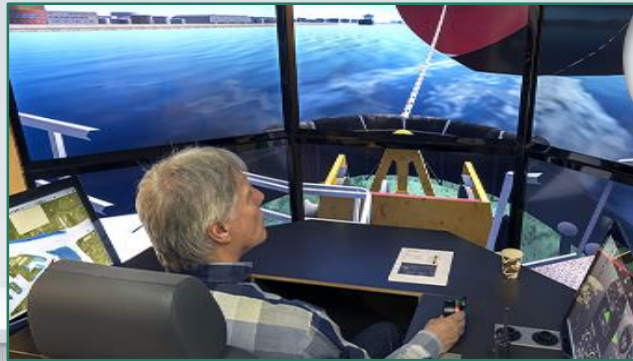
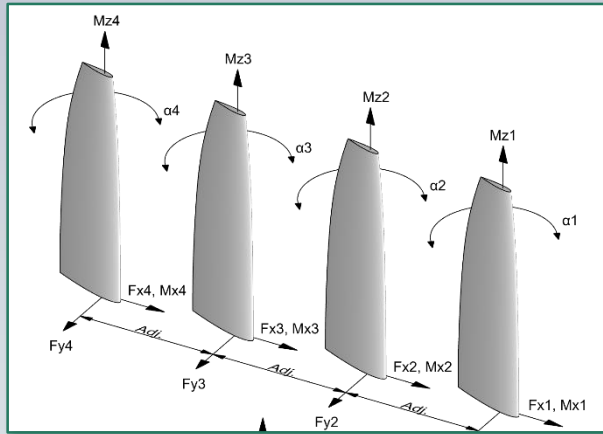

Prestanda

Risk

Logistik

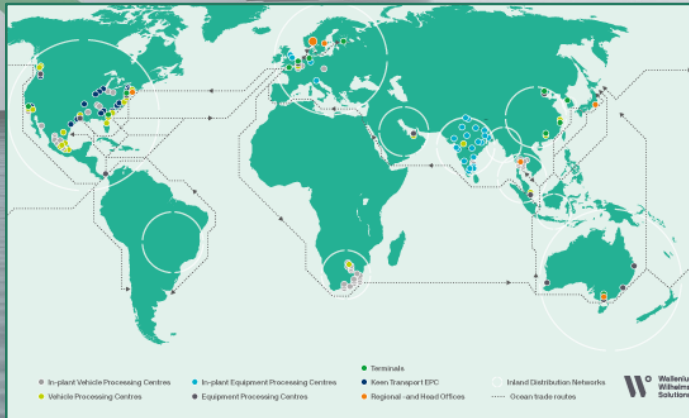

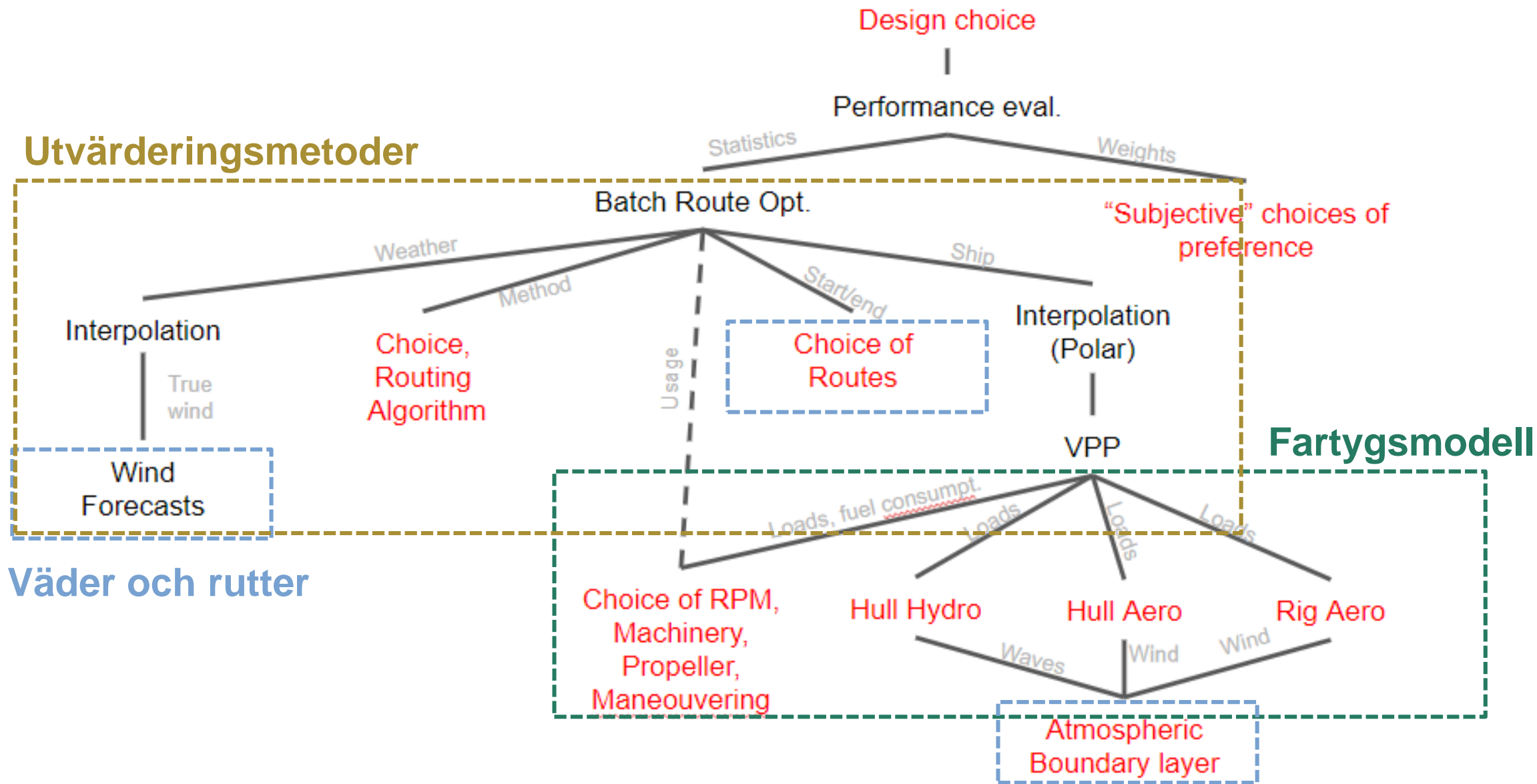

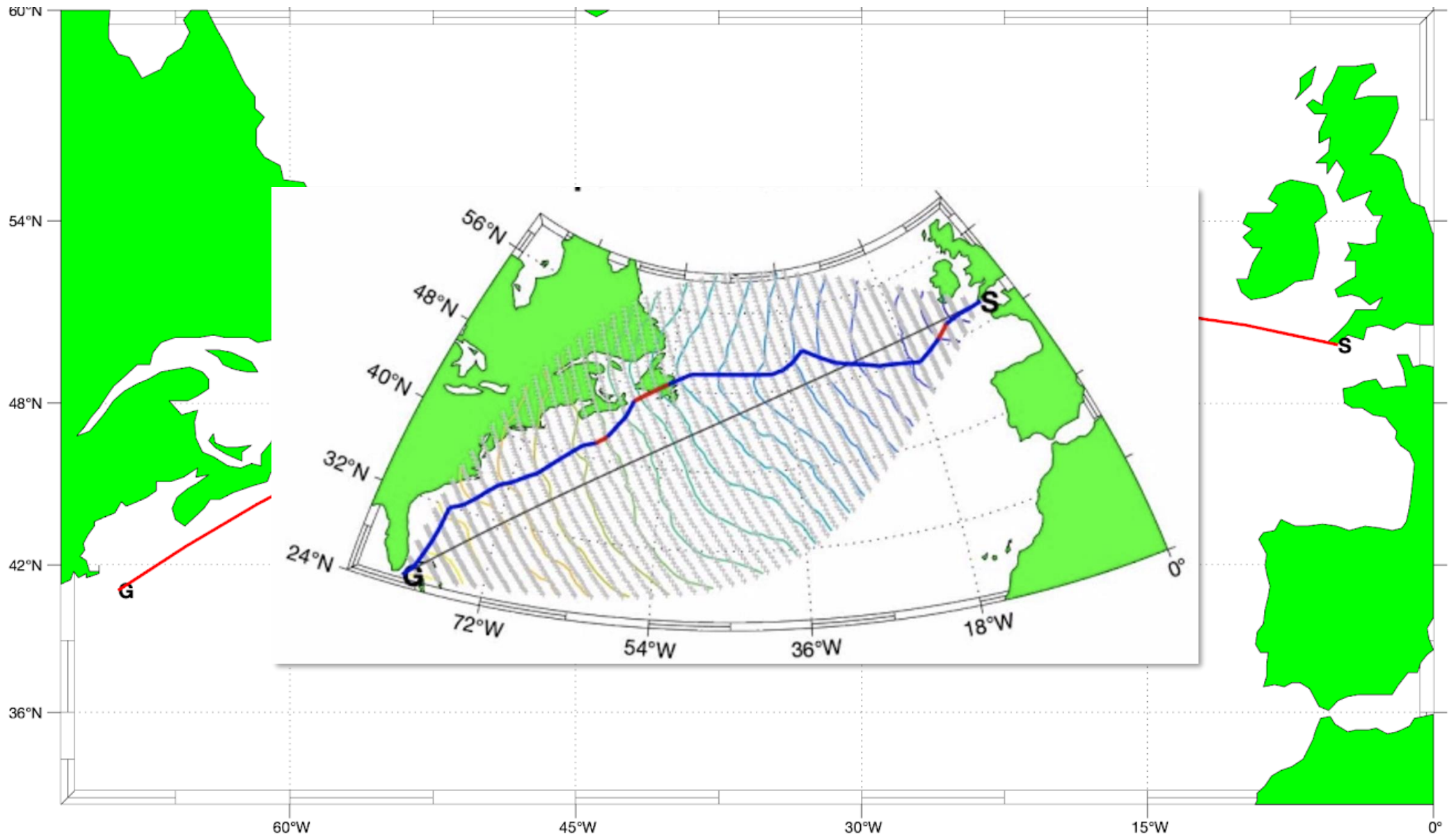

# Routes-04.mat, Statistics from 106 routes with 1484 legs at $V_{s_{min}}=0kn$

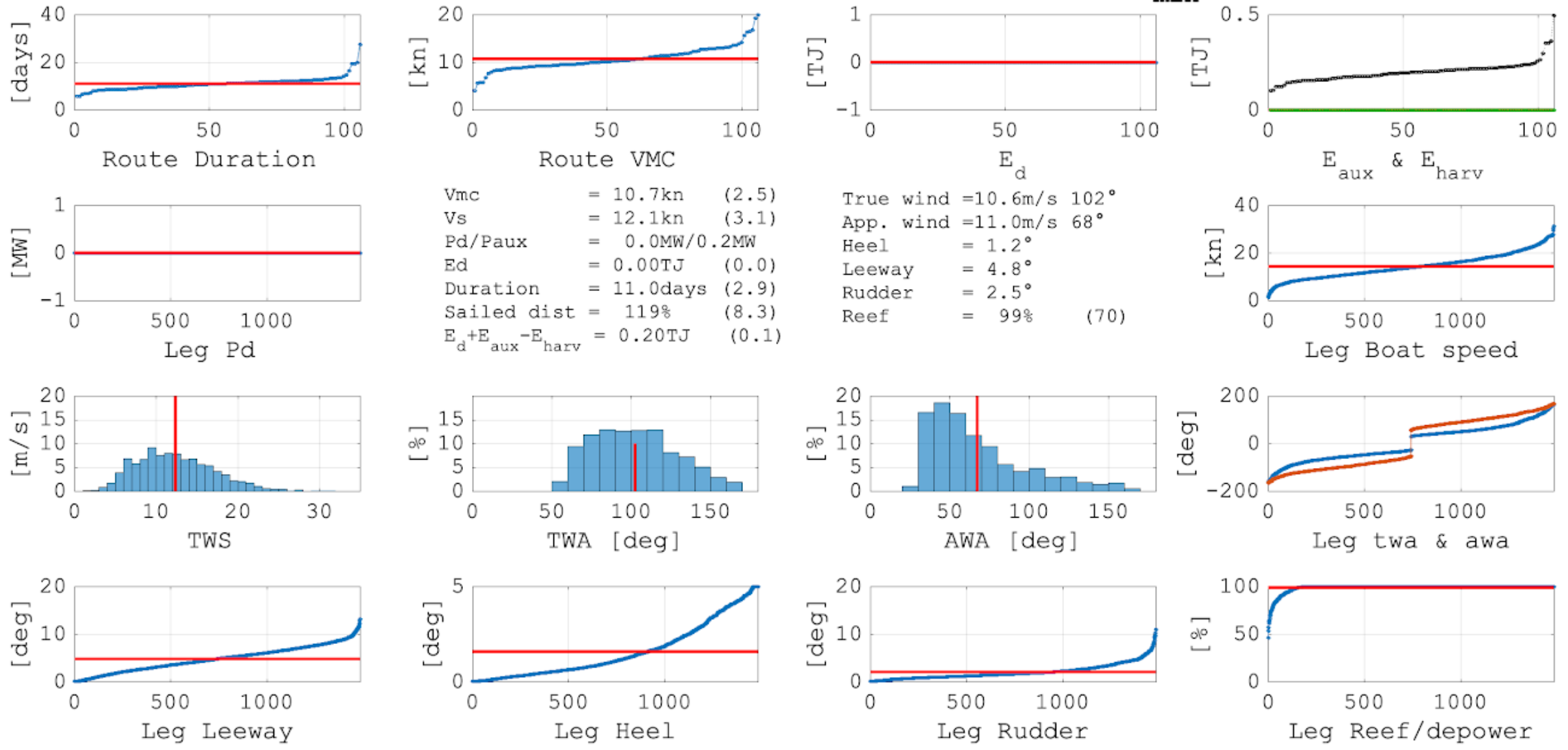

Routes-04.mat, Statistics from 106 routes with 1484 legs at  $V_{s_{min}}=0kn$

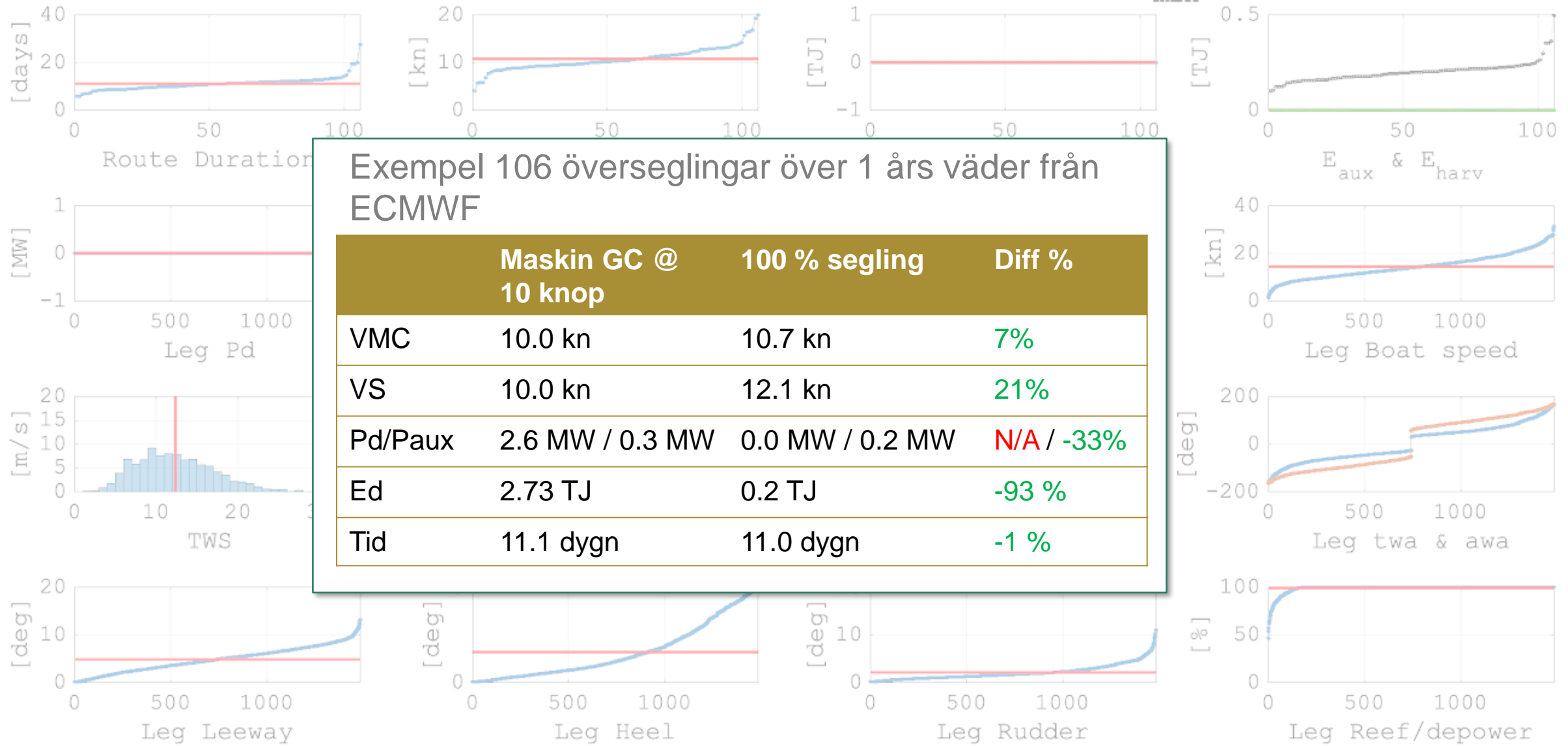

**Exempel 106 överseglingar över 1 års väder från ECMWF**

	Maskin GC @ 10 knop	100 % segling	Diff %
VMC	10.0 kn	10.7 kn	7%
VS	10.0 kn	12.1 kn	21%
Pd/Paux	2.6 MW / 0.3 MW	0.0 MW / 0.2 MW	N/A / -33%
Ed	2.73 TJ	0.2 TJ	-93 %
Tid	11.1 dygn	11.0 dygn	-1 %

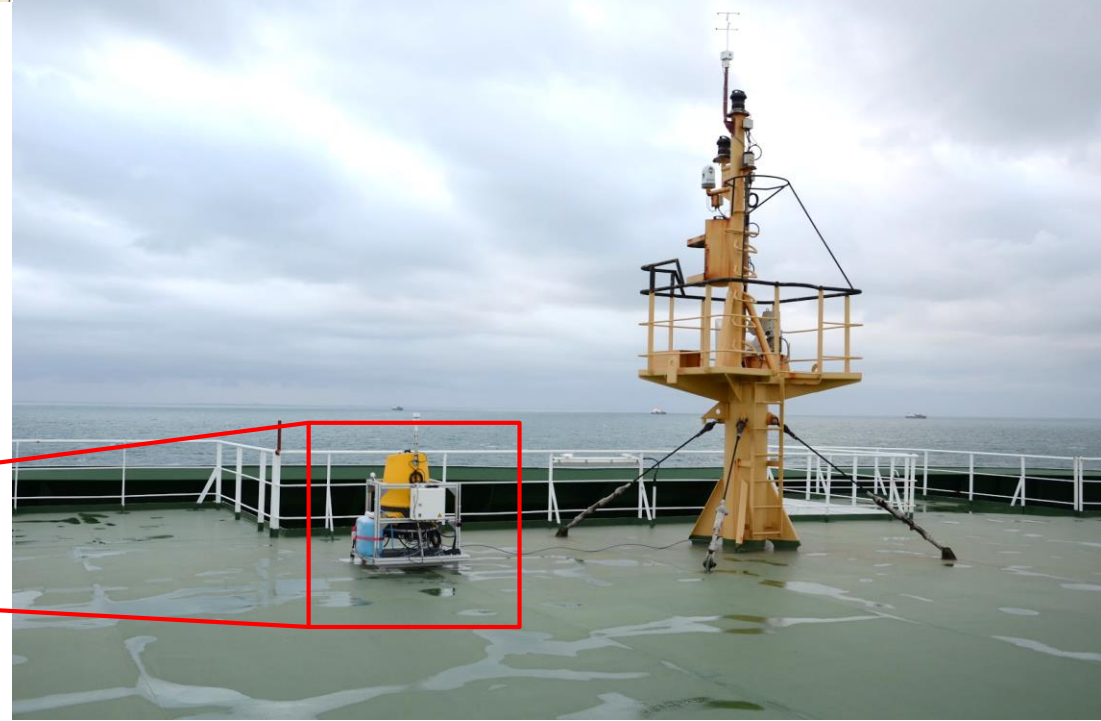
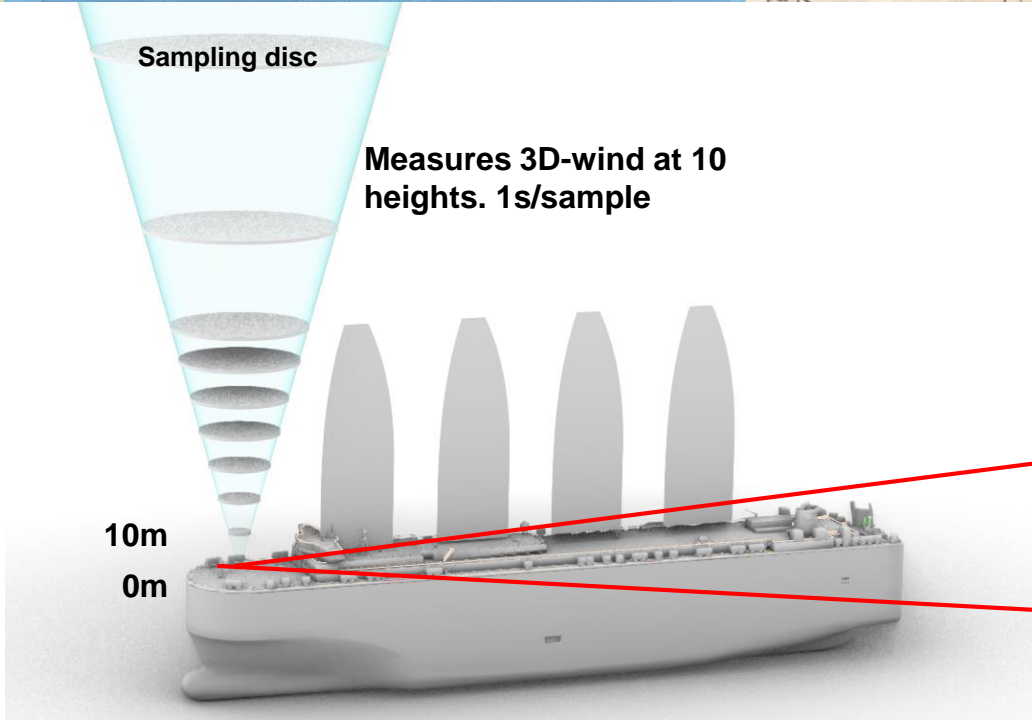
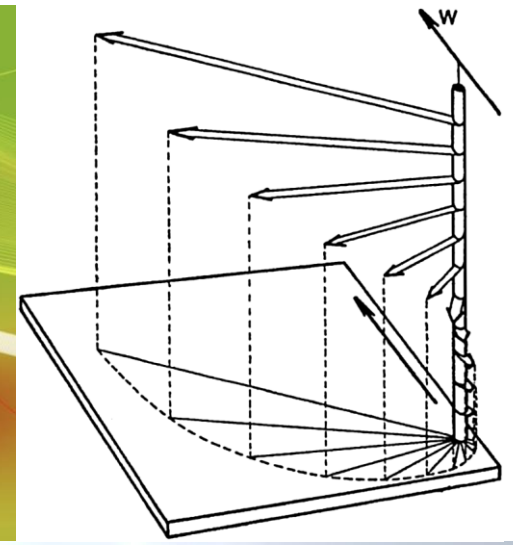
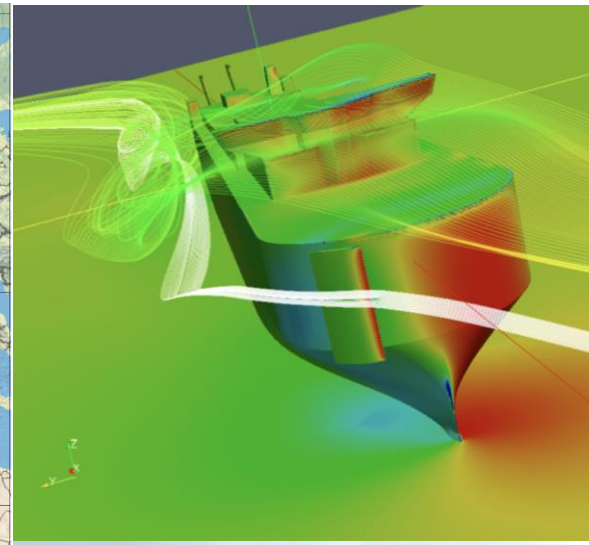
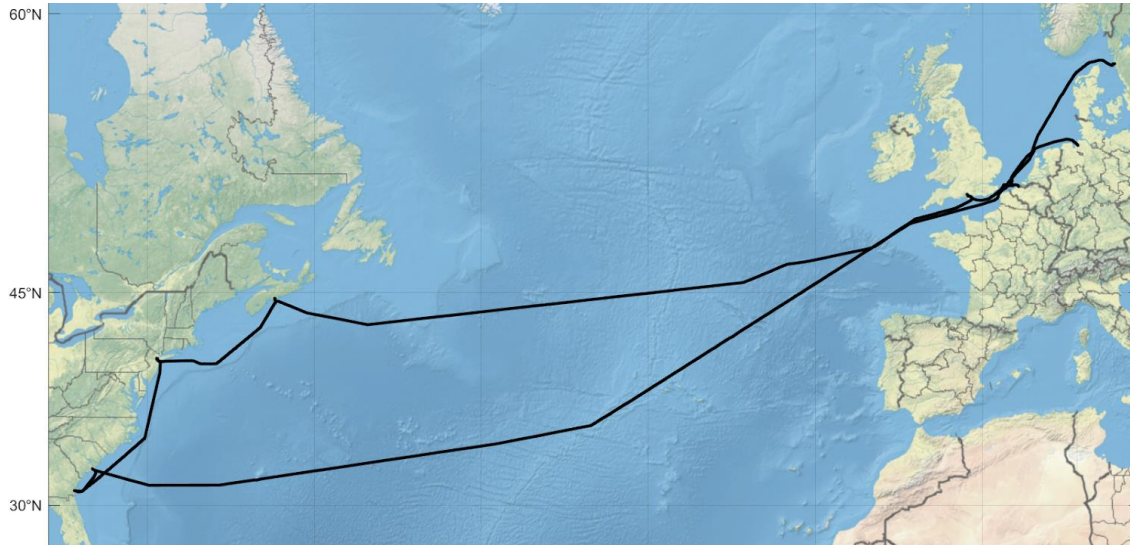

# DEMONSTRATIONS PROJEKT

Varför:

- Verifiera antaganden
- Skaffa mätdata
- Testa manövrering
- Testa kontrollsystem
- Utvärdera risker
- Testa egenskaper
- ...

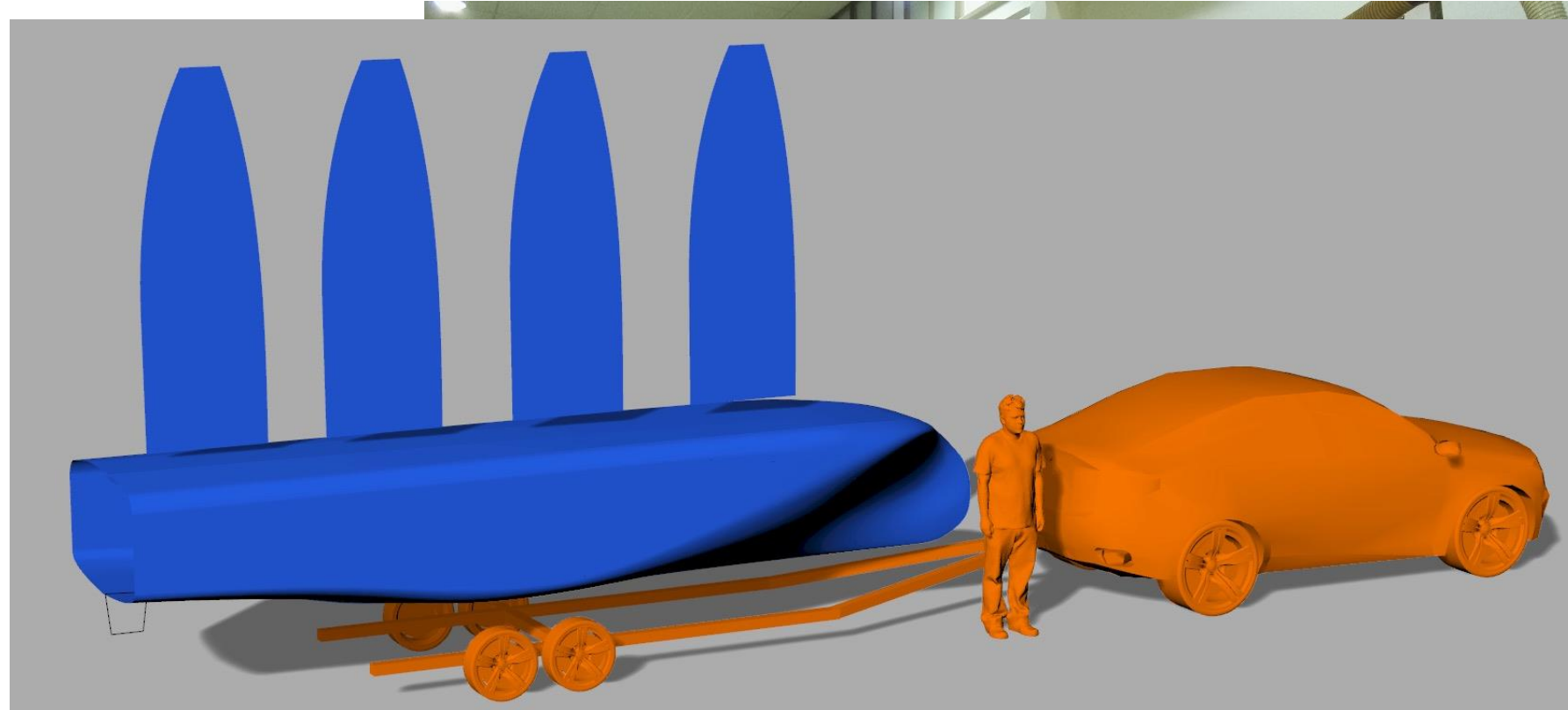

Troliga demonstratorer:

- Mindre självseglande modell
- Rigg i halvskala på existerande fartyg



# UTMANA TRADITIONERNA – MOT VERKLIGT HÅLLBAR SJÖFART

- Vind som huvudsaklig framdrift
- 90% lägre energianvändning
- 10 knots medelhastighet
- F&I finansiering från Trafikverket
- Färdig för beställning 2021/22





WALLENIUS  MARINE

Tack för er uppmärksamhet!



Leading the way towards truly sustainable shipping