

NPA 2018-11

Certification Specifications and Guidance
Material for maintenance certifying staff type
rating training (CS-MCSD)

Jukka Salo
Flygteknisk Inspektör
jukka.salo@transportstyrelsen.se

(CS-MCSD)

The objective of this Notice of Proposed Amendment (NPA) is to;

- improve the level of safety related to the minimum syllabus of maintenance certifying staff (MCS) type rating training (TRT),
- enabling design approval holders (DAHs) that comply with Annex I (Part 21) of Regulation (EU) No 748/2012 to identify the technical elements necessary to be addressed for the purpose of training of maintenance certifying staff involved in the maintenance of their products.

In addition, the intent is to ensure an adequate minimum syllabus standard at organisations that comply with **Annex IV (Part-147)** to Regulation (EU) No 1321/2014.

Why we need to change the rules — issue/rationale

- Article 19 ‘Airworthiness’ of **REGULATION (EU) 2018/1139** requires that TCHs provide the minimum syllabus for the type training of the MCS. (Article 5.5 in 216/2008)



This NPA proposes:



- — the first issue of Certification Specification on MCS data (CS-MCSD) and the associated Guidance Material (GM);
- — the amending text for the GM to Part 21 applicable to Operational Suitability DATA (OSD)-MCSD that establishes guidance for the classification of changes to OSD-MCSD in accordance with Part 21.A.
- These proposals are expected to enhance safety and mitigate risk related to maintenance errors due to inadequate training and to establish a TRT minimum standard.

CS MCSD.050 Scope

These certification specifications for maintenance certifying staff data (CS-MCSD) address:

- (a) the determination of a maintenance certifying staff type rating:
 - (1) to assign a maintenance **licence type rating endorsement** for a candidate aircraft.
 - (2) to establish if a candidate aircraft is recognised as **variant or requires a type rating different** from an existing aircraft;
- (b) the minimum syllabus of maintenance certifying staff type rating training.

In summary — why and what

- establish the same level of standard for the concerned TRT among the Part-147 (AMTO);
- facilitate the approval of the TRT by NAAs;
- provide appropriate content and references for an easy integration with Appendix III to Part-66;
- leave enough room to end-users Part-147 AMTO to develop the final TRT according to their local organisation capability; and
- give TCHs the opportunity to voluntarily provide more training elements as recommendations.

Status of provided data - OSD box concept

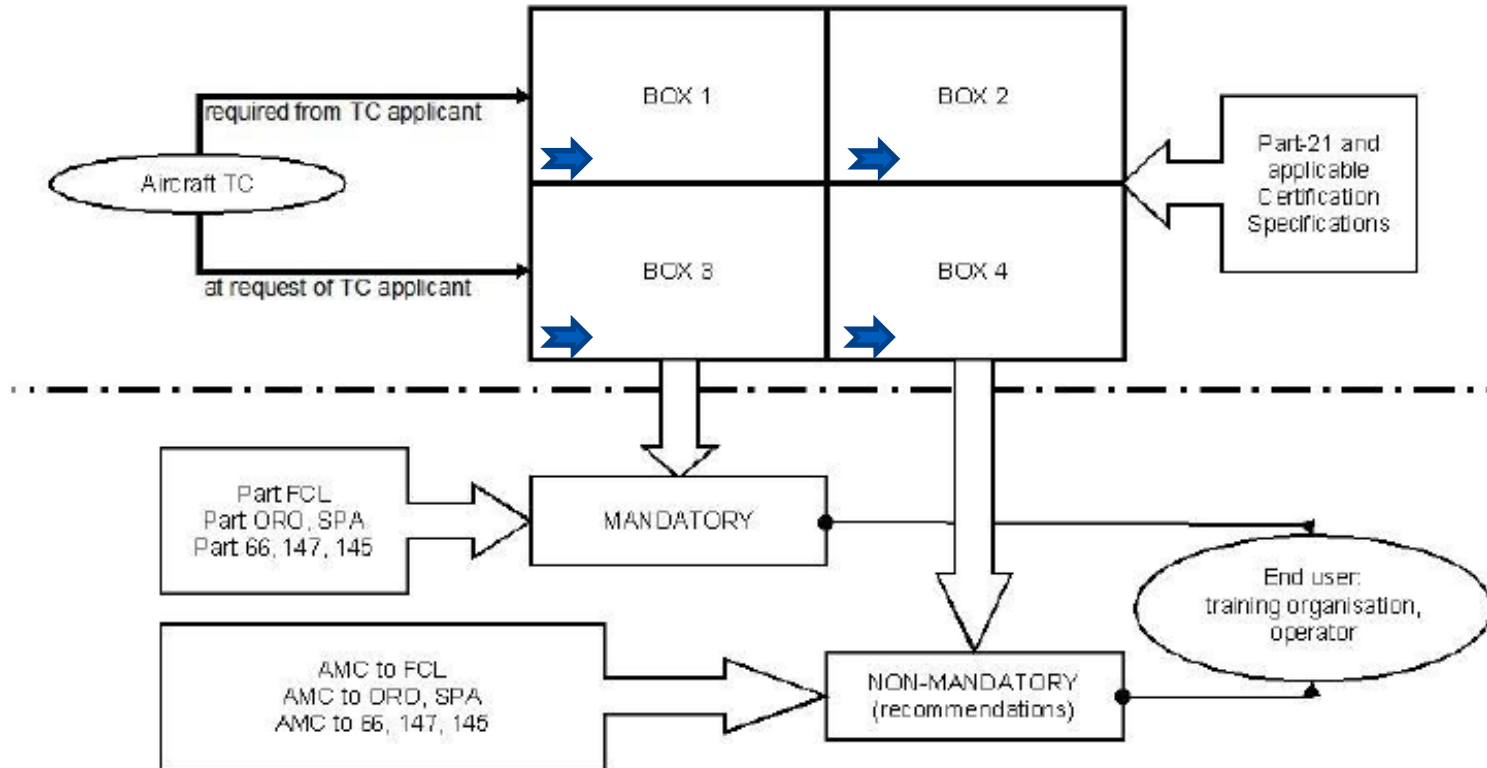

CS MCSD.400 Box 1 Content

- The Box 1 content is constituted by:
- (a) Aircraft maintenance configuration;
- (b) Minimum list of practical tasks;
- (c) Maintenance areas of special emphasis (MASE).

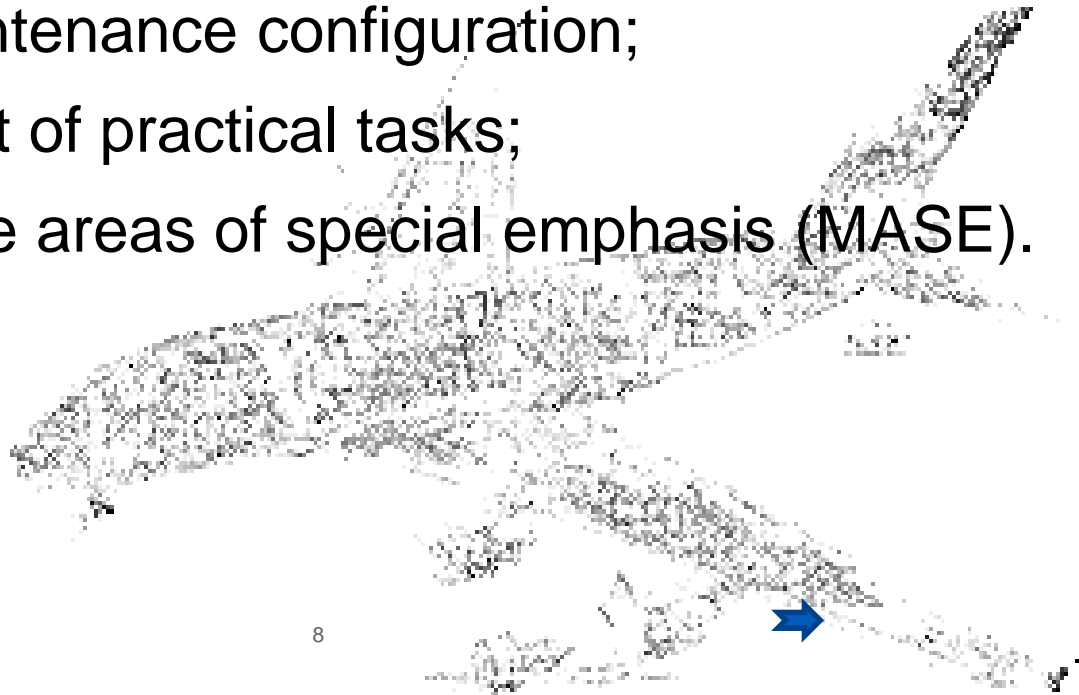

CS MCSD.500 Box 2 Content

- The logical training sequence is the timewise order of imparting training elements of the minimum syllabus.
- References (literature) to new technology. In case of **designs including new technologies, materials and system not covered by the basic training**, the applicant should provide the relevant information necessary to develop training and fill the gap.



CS MCSD.600 Box 3 Content

- Any element that, in addition to those grouped in Box 1, the applicant considers that should be part of the mandatory syllabus of the TRT.



CS MCSD.700 Box 4 Content

- Any other additional elements (i.e. in addition to and beyond the Box1, Box2 and Box3 content) which the type certificate holder recommends to the OSD-MCS user.



Appendix I to CS-MCSD – Minimum Syllabus template

It is recommended to use a tabular format for the minimum syllabus for a proper implementation of the end user training needs analysis (TNA).

A possible template is represented in the table below:

ATA ⁽¹⁾	SUBJECT	PRACTICAL TASK ⁽²⁾	MASE? ⁽³⁾	Variant Applicability
04-00	AIR VEHICLE AIRWORTHINESS LIMITATIONS			
05-00	TIME LIMITS/ MAINTENANCE CHECKS			
05-10	Time Limits			
05-20	Scheduled Maintenance Checks			
05-50	Unscheduled Maintenance checks			
06-00	DIMENSIONS AND AREAS			
07-00	LIFTING & SHORING			
07-10	Jacking			
07-20	Shoring			
08-00	LEVELING & WEIGHING			
08-10	Weighing and Balancing			
08-20	Levelling			

In summary — why and what

- establish the same level of standard for the concerned TRT among the Part-147 (AMTO);
- facilitate the approval of the TRT by NAAs;
- provide appropriate content and references for an easy integration with Appendix III to Part-66;
- leave enough room to end-users Part-147 AMTO to develop the final TRT according to their local organisation capability; and
- give TCHs the opportunity to voluntarily provide more training elements as recommendations.

Frågor?